



Siemens PLM Software

Tecnomatix Dimensional Planning and Validation (DPV)

Benefits

- Reduce cost required to achieve your quality targets by facilitating quick problem resolution
- Decrease time-to-market and factory downtime by providing in-depth analysis of build issues
- Increase end product quality by enforcing data consistency
- Boost productivity by enabling enterprise design and manufacturing on a truly global basis

Summary

To enable your extended enterprise to collect, manage, dimensionally analyze and report on quality measurement information, Siemens PLM Software provides Tecnomatix® Dimension Planning and Validation (DPV) software. This user-friendly solution significantly reduces your bottom line manufacturing and quality costs by giving decision makers rapid access to design and manufacturing information that directly influences your enterprise's quality targets.

Incorporating quality management into your product lifecycle

Siemens' Tecnomatix DPV solution directly addresses the cost and speed of bringing high quality products to market in a demanding global marketplace. By enabling decision makers to quickly understand the quality measurement information associated with your enterprise's design and manufacturing operations, Tecnomatix DPV plays a major role in reducing the overall cost of quality.

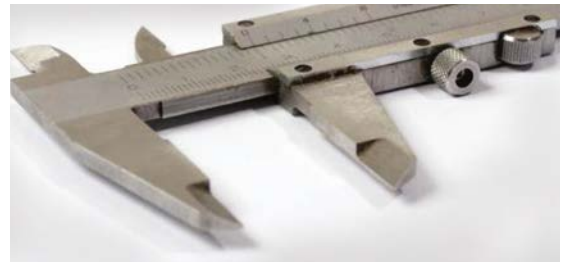

Tecnomatix Dimensional Planning and Validation (DPV)

Features

- Enterprise-wide visibility to quality information
- Integrated definition of your measurement process coordinated with product design, manufacturing planning and plant layout
- In-depth analysis of captured measurement information
- Associative reporting, with standard and on-demand reports generated in seconds
- Historical and summary measurement reporting
- Real-time feeds to live reports of production quality metrics
- Traceability of production measurement information
- User-configured production measurement attributes



Tecnomatix DPV goes beyond the limitations of fragmented quality solutions and closes the loop between design and production, giving you the ability to directly connect and integrate quality knowledge into your company's mainstream product design and manufacturing processes.

A scalable approach for integrating your enterprise

Tecnomatix DPV utilizes Teamcenter® software, Siemens' solution for integrating your product lifecycle management (PLM) capabilities in a single seamless environment. This enables you to incorporate as-built production information in the same

environment you use to manage your enterprise's product, process and manufacturing data.

As a result, you can extend your quality process across your entire enterprise and supply chain, allowing you to design anywhere, build anywhere and sell anywhere with confidence.

With these enterprise capabilities in place, you can bring more innovative products to market faster and leverage the power of your global manufacturing operations while using Tecnomatix DPV's decision-support capabilities to improve product quality and increase production efficiency.

How Tecnomatix DPV works for you

You can use the following Tecnomatix DPV capabilities to plan and monitor quality throughout your enterprise.

Measurement planning – you can manage, update and capture as-designed measurement points and measurement plans in a manufacturing database that decision makers can access at anytime and from anywhere for selected information retrieval.

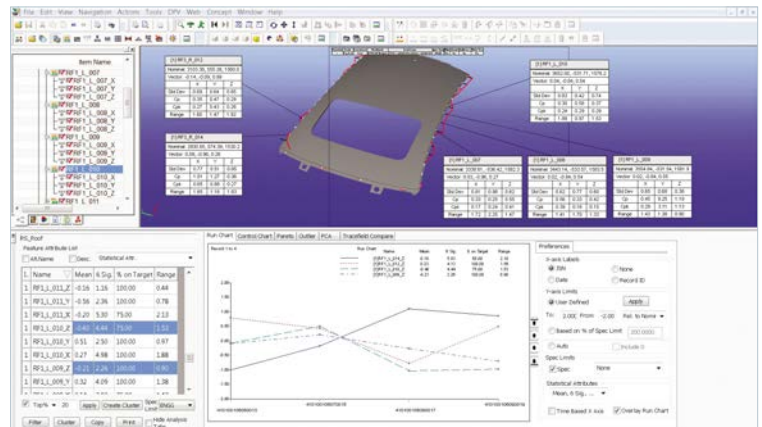
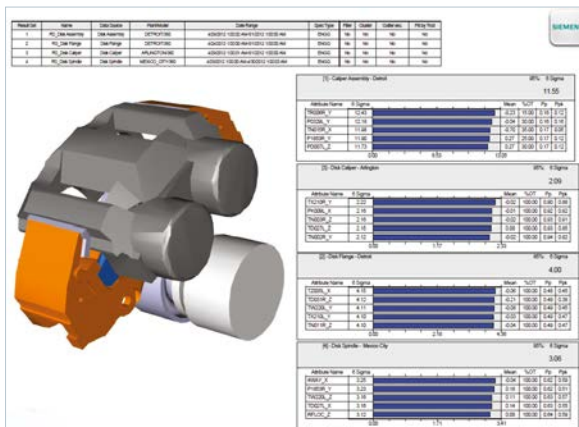

Production monitoring – you can capture measurement data from any device into Teamcenter. During the loading process, you can use automated tools to proactively identify quality trends.

Historical reports – you can produce summary reports to consolidate extremely large amounts of measurement data, enabling decision makers to quickly review this information. You can use this information to compare processes and/or plants, understand process stability and summarize your company's performance over any time period.

Analysis – you can combine Tecnomatix DPV's easy-to-use but sophisticated statistical techniques with your PLM environment's 3D geometry capabilities to enable quality teams to rapidly define root causes to quality issues found in production.

Automated report publishing – you can use Tecnomatix DPV to automatically populate preconfigured report templates with the quality measurements. You can then disseminate these reports from the shop floor to the boardroom so that decision makers can make metrics-based design and manufacturing decisions.

Web-enabled presentation and collaboration – you can provide decision makers with Tecnomatix DPV's simple-to-navigate front end so they can access all quality reports using nothing more than an everyday web browser.

The Tecnomatix DPV advantage

While you can derive numerous benefits from using Tecnomatix DPV, the following four advantages are particularly important from a business perspective.

Advantage	How Tecnomatix DPV delivers this advantage
Reduced cost of quality	Tecnomatix DPV enables you to resolve quality issues early in the product lifecycle before quality problems adversely affect product quality, operational productivity or your warranty costs.
Beating your competition to market	Tecnomatix DPV enables you to introduce saleable quality into your product offerings at a faster rate than your competition by leveraging the same Teamcenter capabilities that drive your concurrent engineering and lean manufacturing initiatives.
Increased market share	Tecnomatix DPV enables you to deliver higher quality products by providing decision makers with complete visibility into all of your quality information.
Proven success	When you buy Tecnomatix DPV, you are buying from the same vendor that provides Teamcenter – the world's most widely deployed PLM system.

Contact

Siemens PLM Software
 Americas +1 314 264 8499
 Europe +44 (0) 1276 413200
 Asia-Pacific +852 2230 3308

www.siemens.com/plm

© 2014 Siemens Product Lifecycle Management Software Inc. Siemens and the Siemens logo are registered trademarks of Siemens AG. D-Cubed, Femap, Fibersim, Geolus, GO PLM, I-deas, JT, NX, Parasolid, Solid Edge, Syncrofit, Teamcenter and Tecnomatix are trademarks or registered trademarks of Siemens Product Lifecycle Management Software Inc. or its subsidiaries in the United States and in other countries. All other logos, trademarks, registered trademarks or service marks belong to their respective holders.
 12276-Y7 11/14 B