



Siemens PLM Software

## NX Mold Design

The fastest and most complete mold design process

### Benefits

- Formalize your design process
- Leverage highly automated core/cavity design
- Capture tooling design knowledge and re-use proven designs
- Leverage a comprehensive mold base, molding component system and standard part design
- Facilitate fast and efficient design change propagation across entire process (tool design through machining)
- Virtually prototype functional tooling operations
- Reduce tool design errors
- Collaborate with customers and suppliers

### Summary

NX™ Mold Design software delivers a state-of-the-art solution that enables mold manufacturers to shrink their lead times and tighten their cost controls. By combining industry knowledge and best practices with process automation, NX Mold Design streamlines the entire mold development process: from part design to tool assembly layout, tool design and tool validation. NX Mold Design excels at even the most challenging mold designs, providing advanced functionality, step-by-step guidance and associativity with part designs to ensure fast response to design changes and quality molds.

### Tooling process expertise

#### Product analysis

Import part geometry and drawings using data translators. Easily model and perform design changes to ensure desired design intent and achieve manufacturability.

Core cavity development Automate shut-offs and parting of core/cavity based on

manufacturability considerations. Design parting surfaces quickly and associatively. Split mold to accommodate complex slider designs. Automatically check the core/cavity design for interferences.

### Mold structure

Layout the core, cavity, component systems and mold base for both prototype and production-scale multi-cavity molds. Configure the mold based on libraries of standard parts, component systems and mold bases. Easily configure library content without programming. Design sliders and lifters. Quickly add and trim ejector pins. Insert cooling

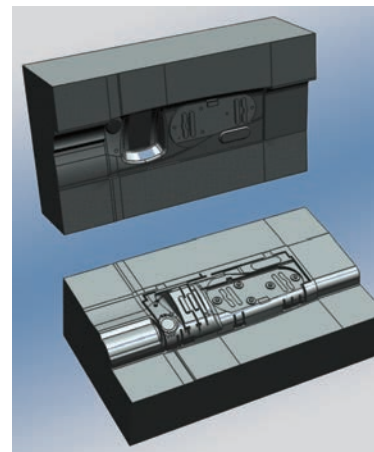

*Effective parting surface and patching functions automate the core and cavity design.*

# NX Mold Design

## Benefits *continued*

- Standardize the quotation process
- Reduce CNC programming time
- Eliminate conventional drawings – achieve paperless processes
- Centralize and control design information

## Key messages

- Embedded process expertise drives productivity and quality with specialized applications and workflows
- Speed and consistency are achieved with re-usable design standards, custom component libraries and standard component libraries
- Confidence and reputation soar when mold designs are validated and verified
- Processes improve when the solution set is integrated

channels with parametric patterns. Include runners, gates, screws, pins and other common library components.

## Detailing

Document the mold design using automated drawing creation with associative hole tables, 3D annotation and hole tolerances. Leverage 3D annotation for paperless communication and manufacturing.

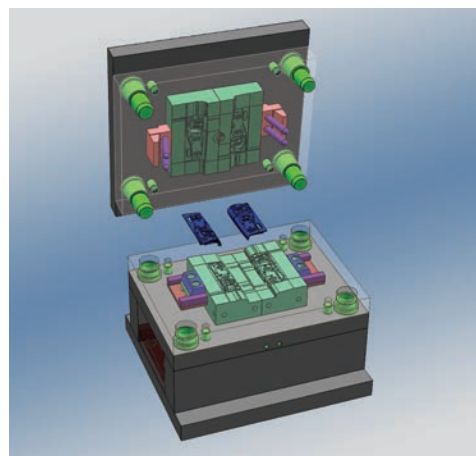

*Comprehensive libraries of mold bases, standard parts and component systems accelerate the complete mold assembly.*

## Scalable expert solution

Take advantage of Siemens PLM Software's comprehensive solution set. Leverage full feature assembling modeling, Xpress review and the Strength Wizard as rich functional capabilities within our Mold Design packages.

## Design change and propagation control

Update design changes quickly by taking advantage of mold development's product design associativity. Leverage Teamcenter® software to keep your whole team working with the right data.

## Re-use of company standards

### Configured inputs

Re-use preconfigured project templates, materials, tools and processes and adapt proven designs to new molds. Accelerate and optimize the mold design process by standardizing processes and components.

## Configured outputs

Automate generation of parts lists, drawings, project data structures and NC toolpaths.

## Re-usable parts

Build your own re-usable parts and register them in custom libraries. Develop your own re-usable mold base configurations too.

## Design validation

### Product analysis

Validate part design for manufacturability using wall thickness checking functions, draft analysis and undercut region detection and radius evaluation.

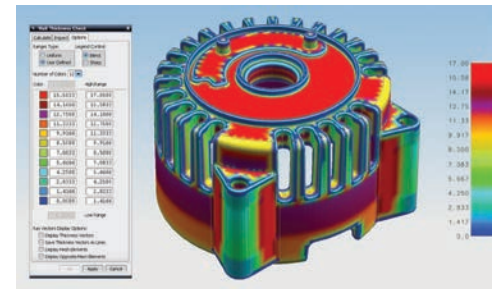

*Analyze parts for wall thickness and moldability considerations. Easily visualize results.*

## Tooling analysis

Validate the mold design within the assembly context for proper clearances and reliefs in various positional states. Analyze the electrode requirements. Improve tool longevity with strength analysis and sharp corner detection.

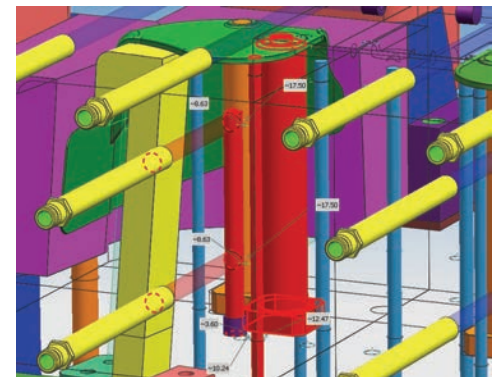

*Analyze, visualize and validate clearances between sets of components within the mold design.*

## Integrated solution

### Design change management

Graphically compare versions of a design for similarities and differences. Swap design versions, control the propagation of change and efficiently update related features, drawings and toolpaths.

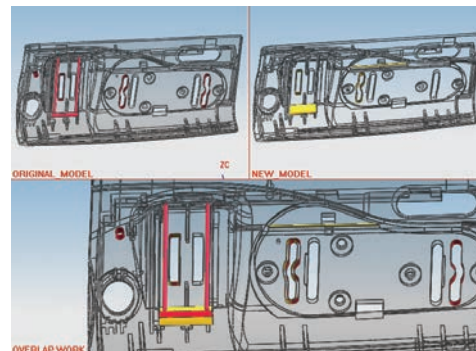

Leverage design change comparison and propagation tools to facilitate high levels of efficiency.

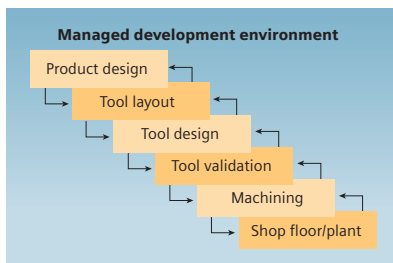

Work concurrently with team members, search, access and re-use project and process data all within the managed development environment.

### Process and data management

Enable team-oriented design with multiple designers working concurrently on a single mold design. Synchronize and distribute product and process data across tool design and manufacturing teams and re-use proven design practices.

### Collaboration

Email lightweight, self-contained viewer files to non-CAD participants in the design process.

### Manufacturing integration

Automate manufacturing processes and operation selection via integration of NX Mold Design and NX CAM.

## NX Mach 3 Mold Design product content

### Mold design

- Shrinkage
- Parting line and surfaces
- Shut-off surfaces
- Core/cavity and region split
- Cooling
- Merge cavities

- Runners and gates
- Subinserts and hole charting
- Sliders/lifters
- Template configuration – re-use
- Ejection
- Concept design
- Automated drawing creation and hole charting
- GD&T, 3D annotation, BOM, hole table, wire EDM start hole
- Design change control

### Standard catalog offerings

- Mold bases supported in English and metric units: DME, Futaba, HASCO, LKM, Meusburger, Omni, PCS, Progressive, Rabourdin, Strack, Superior, Universal
- Standard parts and molding systems supported in English and metric units (injection, ejection, cooling, sliders/lifters, guides, locks, dowels, screws, springs, pillars): DME, Futaba, HASCO, National, Meusburger, Omni, Progressive, Rabourdin, Strack, Yates
- Die base management
- Standard part management

### Validation

- Molded part validation
- Product validation
- Tool validation clearance check
- Parting check

### Part and assembly modeling

- Solid and feature modeling
- DesignLogic
- UDF
- Free form modeling, basic
- Straight break sheet metal
- Assembly modeling
- Free form modeling, advanced
- Synchronous technology

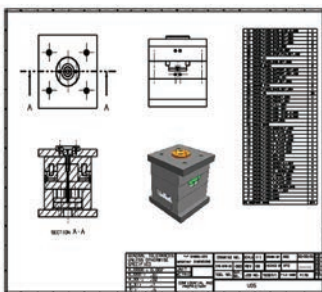
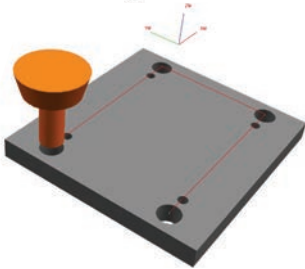
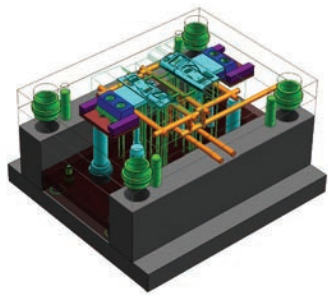
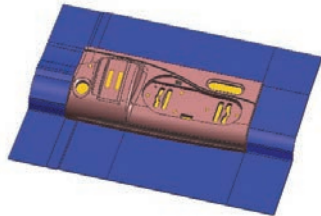

### Managed development environment

- Vaulting and version management of product and process data
- Web infrastructure for data accessibility
- 2D drawing and 3D part and assembly visualization/markup independent of CAD system
- Support for distributed concurrent team design

### Collaboration

- Package design documents for quoting and design review
- Web publishing
- Early supplier involvement template to streamline work with customer data

### Online resources

- Help documentation with tutorials
- Learning Advantage (free and self-paced) – NX Standard Part creation tutorial
- Learning Advantage (free and self-paced) – Mold Base customization guide

### Automation

- NX Open and Knowledge Fusion runtime package

### Translators

- DXF/DWG
- IGES
- STEP AP 203 and AP 214

Contact  
 Siemens PLM Software  
 Americas +1 314 264 8499  
 Europe +44 (0) 1276 413200  
 Asia-Pacific +852 2230 3308

[www.siemens.com/plm](http://www.siemens.com/plm)

© 2014 Siemens Product Lifecycle Management Software Inc. Siemens and the Siemens logo are registered trademarks of Siemens AG. D-Cubed, Femap, Fibersim, Geolus, GO PLM, I-deas, JT, NX, Parasolid, Solid Edge, Syncrofit, Teamcenter and Tecnomatix are trademarks or registered trademarks of Siemens Product Lifecycle Management Software Inc. or its subsidiaries in the United States and in other countries. All other logos, trademarks, registered trademarks or service marks belong to their respective holders.  
 5649-Y3 9/14 B